

PLAN

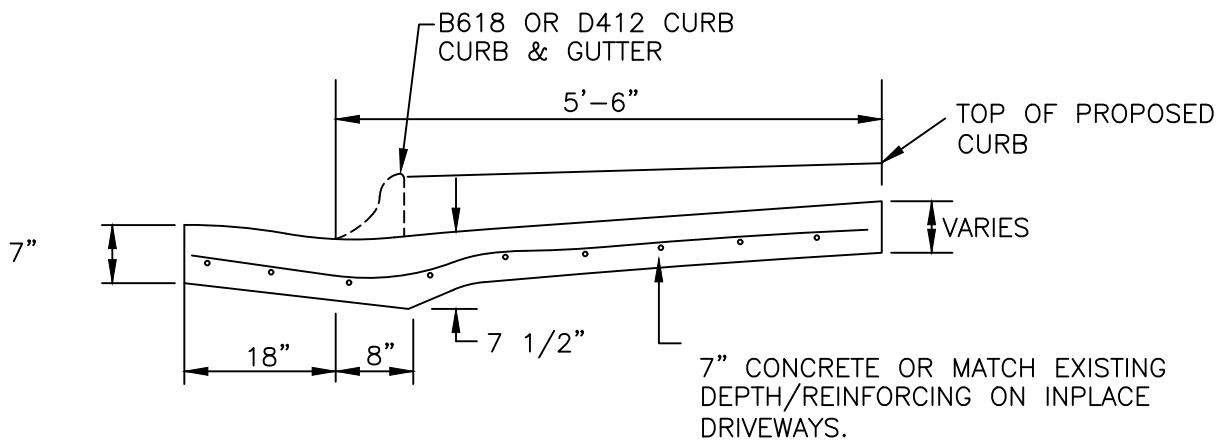

SECTION

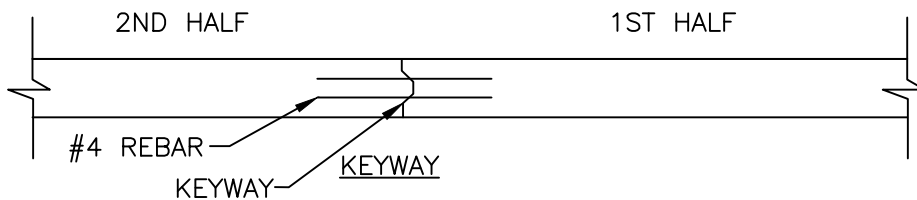

STREET
 INTEGRAL D/W APRON
 COMMERCIAL/INDUSTRIAL
 & PRIVATE STREETS

PLATE NO. LV-ST-4

DATE 02/2024