

HYDRANT LOCATOR TO BE
60" FIBERGLASS HYDRAFINDER
(NO BALL ON TOP)

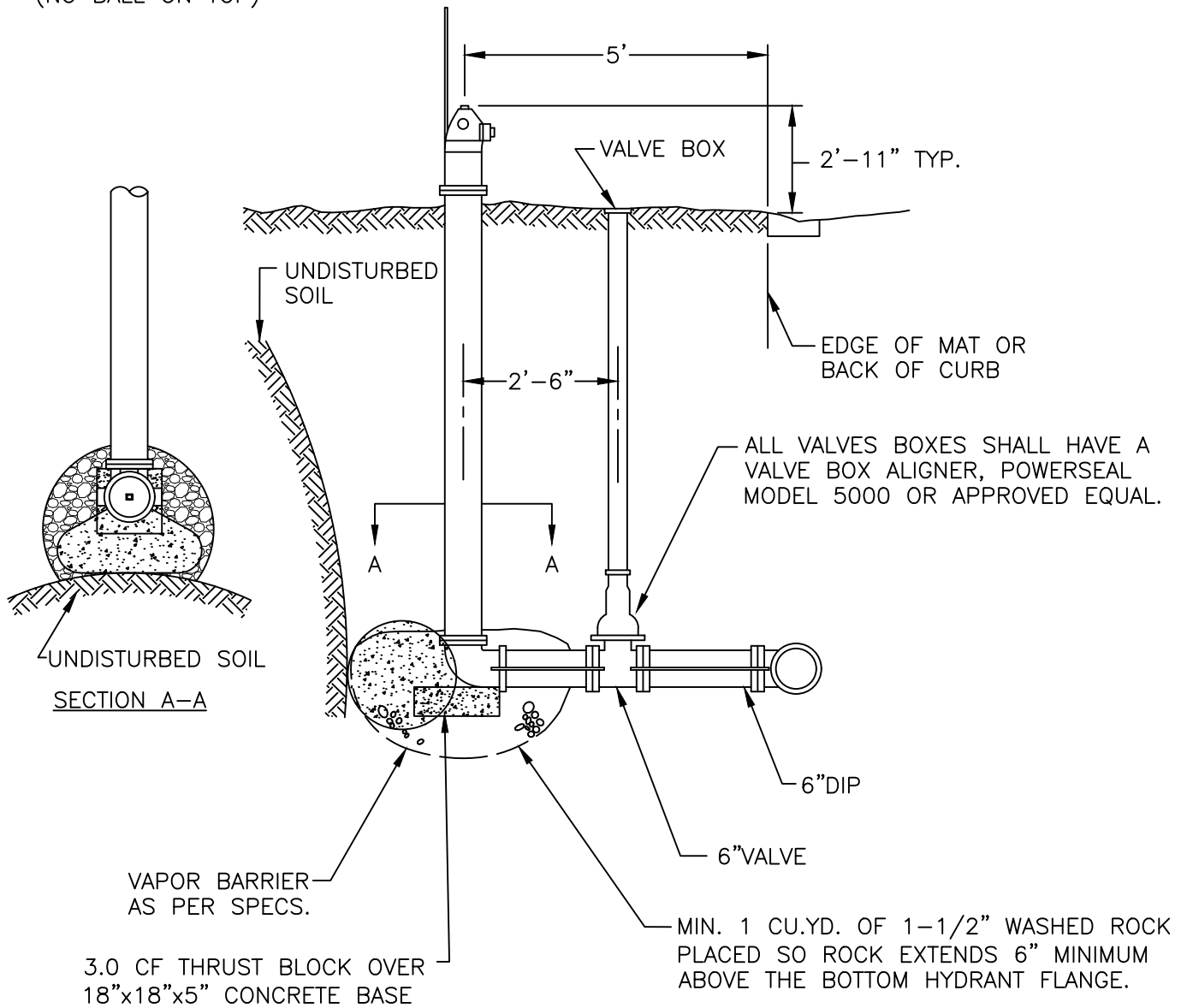

IF A HYDRANT EXTENSION IS ALLOWED, THE CONTRACTOR WILL BE REQUIRED TO REMOVE THE LOWER OPERATING ROD AND INSTALL A NEW ROD TO THE VERTICAL HEIGHT TO INCLUDE THE EXTENSION BEING USED.

MEGA LUGS USED TO TIE ENTIRE HYDRANT ASSEMBLY TO THE MAIN



WATERMAIN
HYDRANT LEAD DETAIL

PLATE NO. LV-WM-4

DATE 02/2024