

① PIPE SUPPORT FROM FLOOR DETAIL

NOTE  
COAT ALL GALVANIZED ITEMS IN CONTACT WITH CONCRETE WITH TWO COATS OF BITUMASTIC PAINT

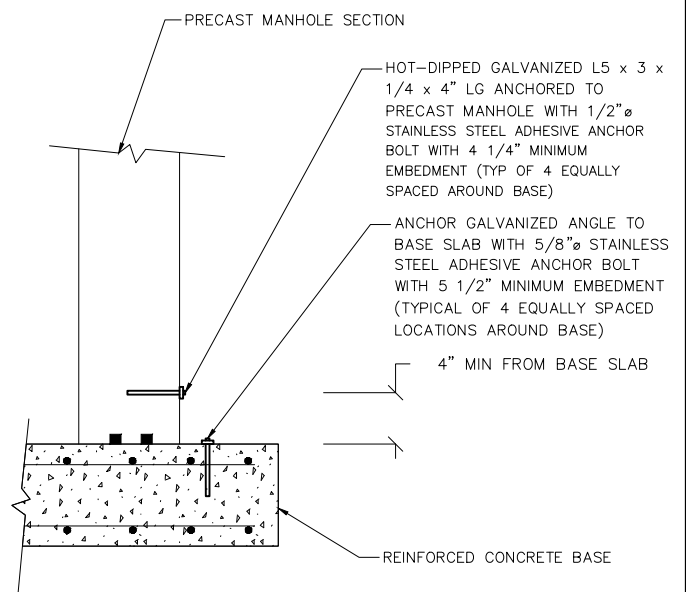

② BASE SLAB ANCHORAGE DETAIL

NOTE  
COAT ALL GALVANIZED ITEMS IN CONTACT WITH CONCRETE WITH TWO COATS OF BITUMASTIC PAINT

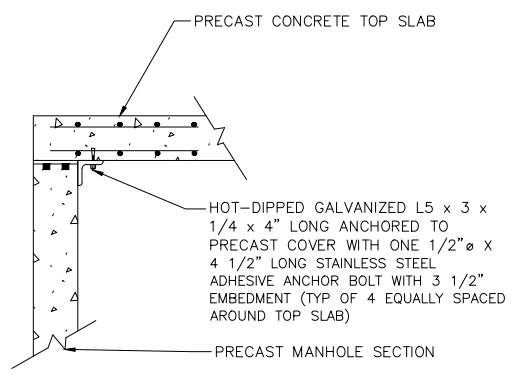

③ TOP SLAB ANCHORAGE DETAIL

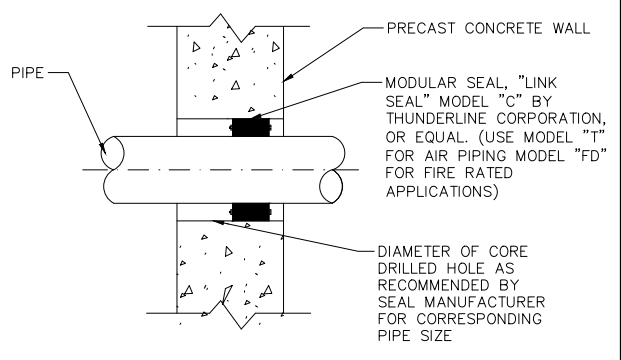

④ PIPE OPENING DETAIL



STANDARD LIFT STATION DETAILS

PLATE NO. LV-SS-14A

DATE 02/2024